

WELL TYPE : SINGLE OIL PRODUCER	RTE :	MAXIMUM DOGLEG :	⊙
FIRST COMPLETED :	SWAB :	MAXIMUM DEVIATION :	⊙
WORKOVER DATE :	KOP :	MINIMUM I.D. :	⊙
WORKOVER NUMBER :	HUD :	AV. ANG. THRU PAY :	
ANNULUS FLUID :	TBG HANGER :	UNITS:	IMPERIAL
FLUID WEIGHT :	REF. LOG :		

CASING & LINER DATA							
SIZE	WT (lb/ft)	GRADE	CONN.	TOP MD	TOP TVD	BTM MD	BTM TVD
13-3/8"	61.0	K-55	VAM			510	
9-5/8"	43.5	N-80	8 RD LTC			4010	
7"	29.0	L-80	BDS	3130		4399	

WELLHEAD DATA		
DESCRIPTION	MAKER	SIZE & PRESSURE
XMAS TREE	GRAY	11" x 4-1/16" 3000 PSI
OFFSET TUBING HEAD ADAPTOR	GRAY	11" x 11" 3000 PSI WITH C/LINE, ELEC. PENETRATOR & PST SLEEVES
TUBING HANGER	GRAY	10" x 4-1/2" 3000 PSI W/BW ELEC. POWER MANDREL PENETRATOR
TUBING HEAD SPOOL	GRAY	13-5/8" x 11" 3000 PSI

TUBING DATA				
SIZE (in)	JOINTS	WT (lb/ft)	GRADE	THREAD TYPE
4-1/2"	97	12.6	L-80	VAM
2-7/8"	17	6.4	L-80	VAM
2-3/8"	27	4.7	P105	HCS

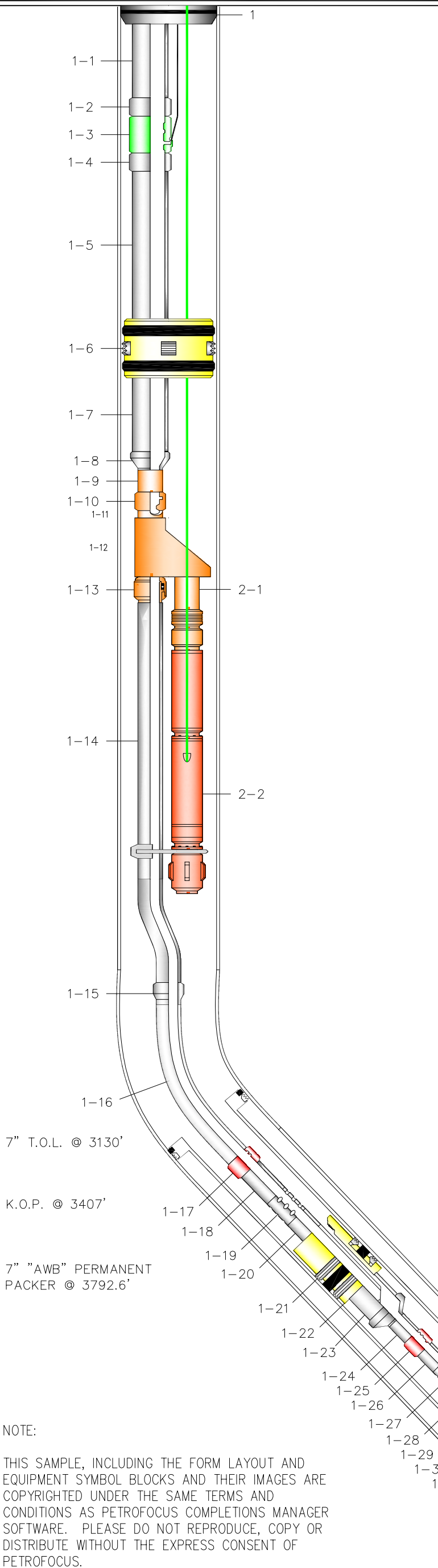

ITEM	DESCRIPTION	MAKER	MODEL	ID	OD	DRIFT	LENGTH	MD	TVD
1	TUBING HANGER, 11" X 4-1/2" WITH ELEC. PENETRATOR	GRAY		3.958	11.000			18	
1-1	TUBING (4 JOINTS), 4-1/2" 12.6 LB/FT VAM, L-80			3.958	4.862			18	
1-2	FLOW COUPLING, 4-1/2" VAM			3.833	4.862			140	
1-3	SSSV LANDING NIPPLE, 4-1/2" X 3.813"	BAKER		3.813	5.580			143	
1-4	FLOW COUPLING, 4-1/2" VAM			3.833	4.862			146	
1-5	TUBING (90 JOINTS), 4-1/2" 12.6 LB/FT VAM, L-80 R3			3.958	4.862			149	
1-6	DUAL HYDRAULIC PACKER, 9-5/8" X 4-1/2" VAM LS X 2-3/8" EUE S.S.	NODECO		3.958	8.500			2894	
1-7	TUBING (3 JOINTS), 4-1/2" 12.6 LB/FT VAM, L-80 R3			3.958	4.862			2905	
1-8	CROSSOVER, 4-1/2" VAM BOX X 3-1/2" VAM PIN			2.880	4.833			2996	
1-9	HANDLING SUB, 3-1/2" VAM BOX X PIN	PHOENIX		2.992	3.900			2998	
1-10	LANDING NIPPLE, 3-1/2" VAM X 2.813" PROFILE SEAL BORE	PHOENIX		2.813	3.540			3001	
1-11									
1-12	Y-TOOL								
1-13	TELE-SWIVEL NIPPLE, 2.75" PROFILE SEAL BORE	PHOENIX		2.750	3.900			3014	
1-14	TUBING (8 JOINTS), 2-7/8" STL.			2.441	2.875			3918	
1-15	CROSSOVER, 2-7/8" STL. BOX X 2-7/8" VAM PIN			2.374	2.875			3258	
1-16	TUBING (16 JOINTS), 2-7/8" 6.4 LB/FT VAM, L-80			2.441	3.197			3250 ??	
1-17	LANDING NIPPLE, 2-7/8" VAM X 2.313" SEAL BORE	OTIS	"X"	2.313	3.227			3747	
1-18	TUBING (1 JOINT), 2-7/8" 6.4 LB/FT VAM, L-80			2.441	3.197			3748	
1-19	PERFORATED JOINT, 2-7/8" VAM X 10'			2.441	3.197			3779	
1-20	PUP JOINT (5 NO'S X 2'), 2-7/8" VAM			2.441	3.197			3789	
1-21	PERMANENT PACKER, 7" @ 3793'	OTIS	"AWB"	3.250	5.687			3793	
1-22	MILLOUT EXTENSION, 8' LONG WITH 2-7/8" VAM PIN			3.670	5.030			3796	
1-23	WIRELINE ENTRY GUIDE, 2-7/8" VAM			2.380	3.197			3799	
1-24	PUP JOINT, 2-7/8" VAM X 10'			2.441	3.197			3804	
1-25	LANDING NIPPLE, 2-7/8" VAM X 2.25" NO-GO	OTIS	"XN"	2.250	3.227			3814	
1-26	PUP JOINT, 2-7/8" X 10' VAM			2.441	3.197			3815	
1-27	PERFORATED JOINT, 2-7/8" X 10' VAM			2.441	3.197			3825	
1-28	CROSSOVER, 2-3/8" VAM PIN X 2-7/8" VAM BOX			1.910	3.226			3836	
1-29	PUP JOINT, 2-3/8" X 10' VAM			1.995	2.697			3837	
1-30	LANDING NIPPLE, 2-3/8" X 1.825" NO-GO VAM	OTIS	"XN"	1.825	2.726			3847	
1-31	CROSSOVER, 2-3/8" HCS PIN X 2-3/8" VAM BOX			1.995	2.594			3848	
1-32	TUBING (27 JOINTS), 2-3/8" 4.7 LB/FT HCS, P105			1.995	2.594			3850	
1-33	CROSSOVER, 2-3/8" VAM PIN X 2-3/8" HCS BOX			1.995	2.594			4685	
1-34	WIRELINE ENTRY GUIDE, 2-3/8" VAM			1.910	2.697			4687	
2-1	PUMP SUB, 3-1/2" VAM PIN X PIN			2.992	3.750			3005	
2-2	ESP								

RTKB 313 FT. AMSL  
 GL 291.8 FT. AMSL  
 THS 293.8 FT. AMSL  
 13-3/8" CHH 291.8 FT. AMSL  
 TD 6550 FT. RTKB  
 PBD 6550 FT. RTKB  
 OBSTRUCTIONS/  
 FISH IN HOLE NONE

**This is a sample drawing.  
 The data is only for  
 viewing purposes.**

THIS SAMPLE, INCLUDING THE FORM LAYOUT AND THE COMPLETION COMPONENT SYMBOL IMAGES ARE COPYRIGHTED UNDER THE SAME TERMS AND CONDITIONS AS PETROFOCUS COMPLETIONS MANGER SOFTWARE. PLEASE DO NOT REPRODUCE, COPY OR DISTRIBUTE WITHOUT THE EXPRESS CONSENT OF PETROFOCUS LTD. WWW.PETROFOCUS.CO.UK

NOTE:  
 THIS SAMPLE, INCLUDING THE FORM LAYOUT AND EQUIPMENT SYMBOL BLOCKS AND THEIR IMAGES ARE COPYRIGHTED UNDER THE SAME TERMS AND CONDITIONS AS PETROFOCUS COMPLETIONS MANGER SOFTWARE. PLEASE DO NOT REPRODUCE, COPY OR DISTRIBUTE WITHOUT THE EXPRESS CONSENT OF PETROFOCUS.

